

Cable Ties

Marker

- **Material:**
- **Application:**
- **Operating Temperature:**

UL approved Nylon 66, 94V-2.
Tie and identify bundles of cable in one operation.
Flat area for imprinting or writing information.
-40°C to +85°C.

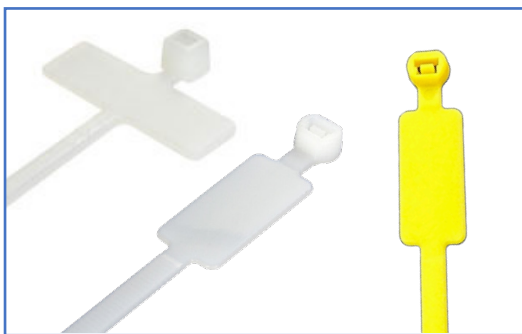

MCT2
MCT3

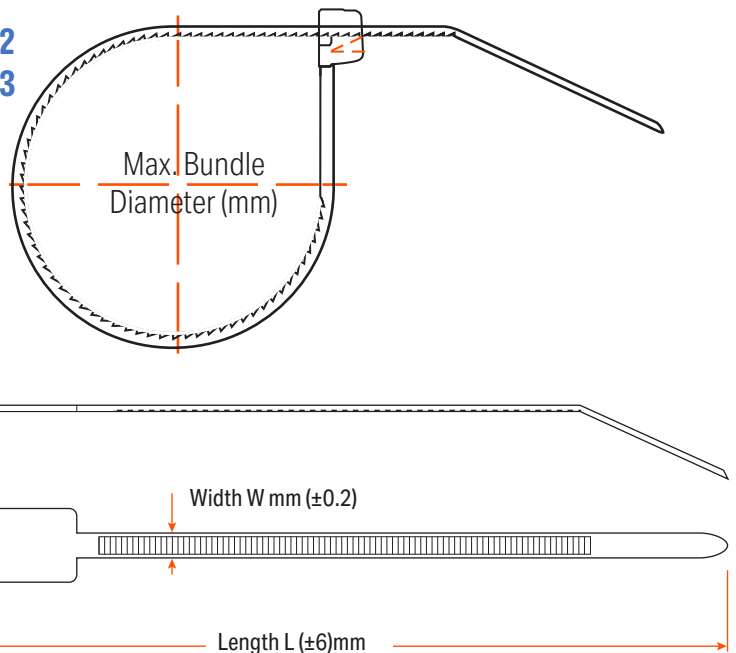

MCT1

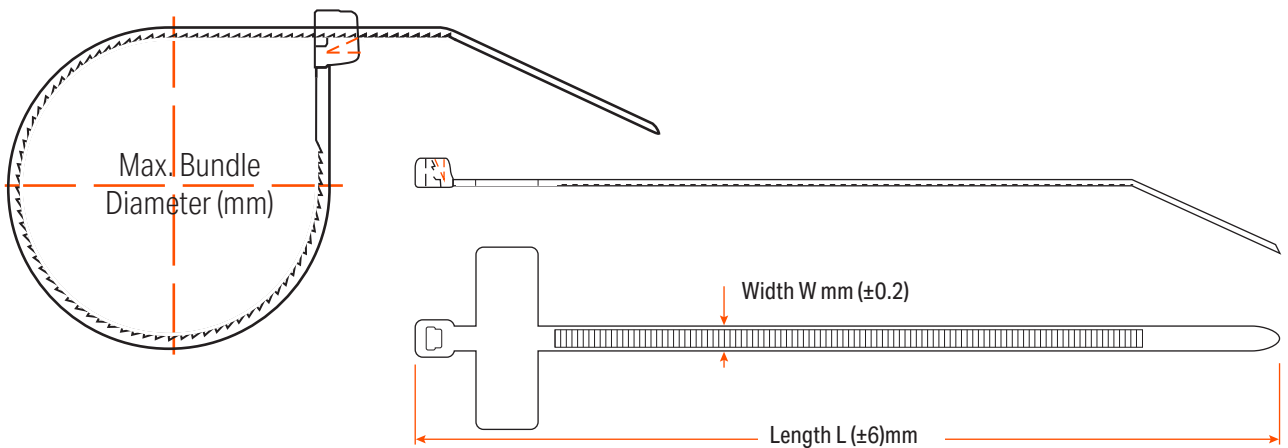

Item No.	Colour	Width W (mm)	Length L (mm)	Max. Bundle Diameter (mm)	Min. Tensile Strength (kg)
MCT1	Natural	2.5	100	23	8
MCT2	Natural	4.8	190	50	22
MCT3	Yellow	4.8	190	50	22

STORAGE AND USAGE OF NYLON CABLE TIES

BEAL UK cable ties are made from high quality Nylon 66 resin. Moisture absorption is an essential factor for this material to retain its strength and maintain optimal performance. To this end, it is important for the cable ties to be kept in a sealed package wherever possible.

Below are some helpful storage suggestions:

1. The ideal storage temperature is around 23°C with the humidity over 50%.
2. Do not open the bag before use. Please try to finish the whole package of cable ties shortly after opening or reseal the bag until you are ready to use again.
3. Do not expose directly under sunlight (except UV weather resistant cable ties).
4. Avoid storing cable ties close to warm objects (such as heaters).